



INSTALLATION AND MAINTENANCE MANUAL FOR GV-305 SANITARY BALL VALVES

INTRODUCTION

The BI-TORQ InstruPak IS-3TC series uses the GV-305 3-piece sanitary ball valve, which provides easy replacement of gaskets, seals and seats without any special tools. The swing-out design of the valve allows for the center section of the valve body to be replaced while leaving the ends clamped in place if necessary.

The SH-305 uses a cavity filler design, which means that the ball can remain completely enclosed by the pure TFE seats, eliminating the chance of product entrapment. Combined with an investment 316L casting, this series of valve is ideal for food, beverage, semi-conductor or pharmaceutical applications. Superior leak protection is accomplished by using a live-loaded packing system featuring belleville washers. An ISO 5211 mounting pad is provided for easy automation.

1. USE

1.1 The life of the valve can be maximized if valve use is within the stated pressure, temperature and corrosion ranges.

2. MANUAL OPERATION

2.1 To open or close the valve, turn the handle 90° (1/4 turn).

- a. Valve in OPEN position: the handle is parallel (in line) with the valve or pipeline.
- b. Valve in CLOSED position: the handle is perpendicular (crossed) with the valve or pipeline.

3. AUTOMATED OPERATION

3.1 Valves with actuators should be checked for stem alignment. Most applications of the IS-3TC valve are direct mount to the actuator, greatly reducing any sideload or increased torque. Make sure that all insert adapters are properly placed on the valve stem and fully engaged in the actuator.

4. GENERAL INFORMATION FOR ON-SITE INSTALLATION

4.1 The valve may be fitted in any position in the pipeline. For automated operation, BI-TORQ does recommend that the valve and actuator be installed vertically in case of valve leakage, although this is not necessary for proper operation of the valve.

4.2 To prevent damage to the seats and ball surface, the pipeline must be flushed so that it is free of dirt, burrs and welding residues before installing the valve.

5. INSTALLATION OF CLAMP END VALVES

5.1 Use the proper clamp and o-ring for pressure range of application.

5.2 Place the o-ring into the o-ring groove on the clamp end.

5.3 Slide the valve between the clamp fittings while making sure that the o-ring remains in place.

5.4 Install the clamp over both valve ends and clamp fitting to insure alignment.

5.5 Tighten both clamps on each valve end.

5.6 Check proper operation of valve (manually or with the actuator).

6. DISSASSEMBLING AND CLEANING THE VALVE

CAUTION: Ball valves can trap fluids in the ball cavity when it is in the closed position. If the valve has been used with hazardous media, it must be decontaminated before disassembly or handling.

WARNING: All persons involved in the removal or disassembly of the valve should wear protective gear such as eye and face protection, gloves, etc.

6.1 Relieve the line pressure.

6.2 Place the valve in the half-open position and flush the line to remove any hazardous material(s) from the valve.

INSTALLATION AND MAINTENANCE MANUAL FOR GV-305 SANITARY BALL VALVES

7. REPLACING THE THRUST WASHER, PACKING AND SEATS

NOTE: The IS-3TC series valve is designed with belleville washers for automatic wear compensation. If there are signs of leakage from the stem, it is time to replace the stem packing and thrust washer.

8.1 Before replacing the thrust washer, seats and the packing, the pipeline must be depressurized.

8.2 Maintenance, removal and replacement of seats and seals is simple even if the valve is installed in line. By removing three of the body bolts and loosening the fourth bolt, the valve body can be swung out of line (SEE ILLUSTRATION 1.1). Seats, seals, gaskets and balls can be replaced without disturbing the pipe alignment.

8. BOLT TIGHTENING SPECIFICATIONS

The body bolts on the valve must be tightened evenly. Tighten the bolts by hand, then use a wrench to tighten bolts in diagonal opposition. See chart 1.2 for bolt torque specifications.

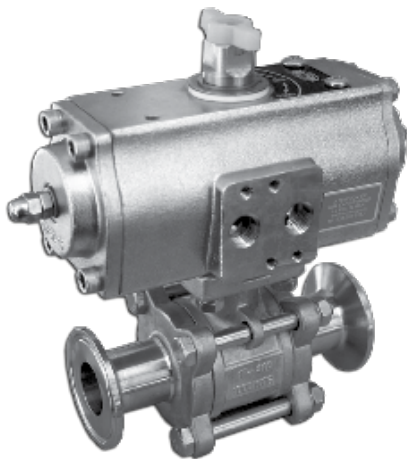

**CHART 1.1:
Bill of Materials**

PART #	NAME	MATERIAL	QTY	ORDER REFERENCE #
1	BODY	CF8M	1	SH-305-***-BODY
2	ENDS	CF8M	2	SH-305-***-ENDS
3	BALL	316SS	1	SH-305-***-BALL
4	SEAT	TFE	1	SH-305-***-RK ¹
5	BODY SEAL	TFE	2	SH-305-***-RK ¹
6	STEM	304SS	1	N/A
7	STEM SEAL	TFE	1	SH-305-***-RK ¹
8	O-RING	VITON	1	SH-305-***-RK ¹
9	STEM PACKING	TFE	1	SH-305-***-RK ¹
10	BELLEVILLE WASHER	304SS	2	N/A
11	STEM NUT	304SS	1	N/A
12	WASHER	304SS	4	N/A
13	NUT	304SS	4	N/A
14	BOLT	304SS	4	N/A

**ILLUSTRATION 1.1:
Swing-out Design**

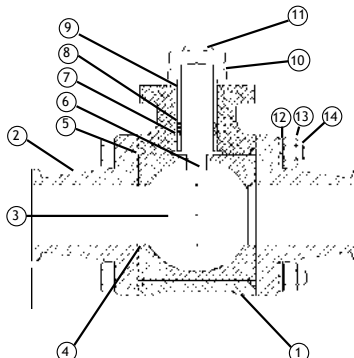
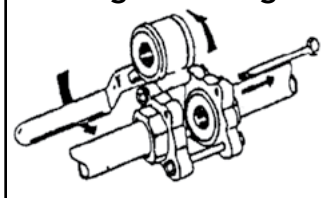

**CHART 1.2:
Bolt Torques**

VALVE SIZE	BODY BOLT TORQUE (IN LBS)
1/4"	44
3/8"	44
1/2"	53
3/4"	62
1"	89
1-1/2"	186
2"	230
2-1/2"	336
3"	487

To order a complete new valve, please refer to BI-TORQ price list for InstruPak valve replacement.

COMPLETE VALVE PART NUMBER: GV-305-***
 ***=VALVE SIZE (002=1/4", 003=3/8", 005=1/2", 007=3/4", 010=1", 012=1-1/4",
 015=1-1/2", 020=2", 025=2-1/2", 030=3")
¹ COMPLETE REPAIR KIT INCLUDES SEATS, SEALS AND O-RINGS