

# MP-2P MANUAL BRASS BALL VALVES



**PRESSURE RATING**  
600 PSI CWP  
**TEMPERATURE RATING**  
+320° F Maximum CWP

- ### VALVE FEATURES
- Full port brass ball valve
  - 1/4" through 4"
  - Blow-out proof stem
  - Chrome plated brass ball
  - Adjustable stem packing
  - ANSI B 1.20.1 connections
  - CSA, UL, NSF and FM approved through 2"

BILL OF MATERIALS			
PART #	NAME	MATERIAL	QTY
1	BODY	BRASS CW 617N UNI EN 12165	1
2	ENDS	BRASS CW 617N UNI EN 12165	2
3	BALL	BRASS CW 617N UNI EN 12165	1
4	SEAT	PTFE	2
5	STEM SEAL	PTFE	2
6	O-RING	NBR 75Sh A	1
7	PACKING GLAND	BRASS CW 614N UNI EN 12164	1
8	NUT	STEEL NS6	1
9	STEM	BRASS CW 614N UNI EN 12164	1
10	LEVER HANDLE	PLATED STEEL*	1

\*2-1/2" THROUGH 4" SIZE USES ALUMINUM HANDLE

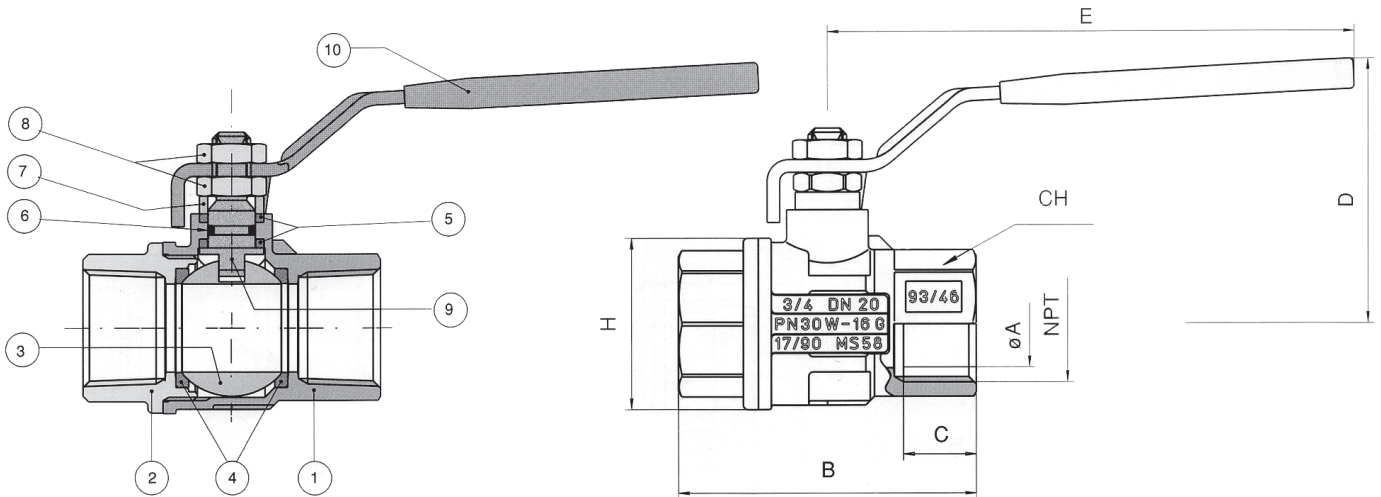

DIMENSIONAL DATA										
SIZE	A	B	C	D	E	H	CH	CV	PSI	WT.
1/4"	0.39	2.02	0.39	1.75	3.85	0.90	0.78	6.29	600	0.30
3/8"	0.39	2.02	0.40	1.75	3.85	0.90	0.78	6.99	600	0.38
1/2"	0.59	2.44	0.53	1.88	3.85	1.25	0.98	19.00	600	0.48
3/4"	0.78	2.71	0.55	2.28	4.80	1.53	1.22	34.42	600	0.79
1"	0.98	3.07	0.66	2.44	4.80	1.92	1.49	50.10	600	1.22
1-1/4"	1.25	3.42	0.68	3.07	6.02	2.32	1.88	103.70	600	2.14
1-1/2"	1.57	3.89	0.68	3.34	6.02	2.87	2.12	268.41	600	3.20
2"	1.96	4.33	0.69	3.79	6.37	3.38	2.63	309.20	600	4.08
2-1/2"	2.56	5.59	1.19	5.02	8.07	4.37	3.54	629.00	600	8.28
3"	3.15	6.45	1.31	5.45	8.07	5.35	4.13	1018.00	600	13.00
4"	3.94	7.60	1.55	6.34	10.23	6.35	5.12	1622.00	600	22.07