



BT SERIES THERMAL SHUT-OFF VALVES

published 2/13/20

OPERATIONS AND MAINTENANCE MANUAL Models FL-BT-149X

I. OVERVIEW OF THERMAL SHUT-OFF VALVES

BI-TORQ Valve Automation automatic thermal shut-off valves are designed for flow shutoff protection in piping systems handling flammable gasses or liquids, solvents, toxic fluids, or any other potentially dangerous media. These fire control valves terminate flow in the event of fire, aiding in reducing fire intensity. In the event of fire, the fusible link separates, allowing the top mounted spring pack to drive an API607 fire safe rated valve into a closed position. Fusible links are available in a range of temperature settings. The thermal shut-off valves also are available in a fail open position, ideal for a sprinkler system in the event of a fire.

The thermal shut-off valves you have received has been assembled and tested at our factory with attention to safety in mind. BI-TORQ Valve Automation uses high quality materials and tested engineering to ensure that this product will operate safely and reliably. Carefully read all instructions before handling in order to avoid injury to the operator or damage to the product.

NOTE: Please refer to the attached assembly drawing FL-BT-0600 for parts identification and complete parts list.

II. GENERAL SAFETY INSTRUCTIONS

WARNING: THIS ASSEMBLY WAS SHIPPED FROM THE FACTORY IN THE UNARMED POSITION AND IS READY FOR INSTALLATION IN LINE. USE EXTREME CAUTION IN HANDLING THE ASSEMBLY BECAUSE THE SPRING PACK IS UNDER FULL TENSION.

NOTE: THE VALVES ARE SHIPPED IN THE CLOSED POSITION.

The unit must be installed in a location with carefully maintained ambient temperatures. Installing the link in locations where high temperature fluctuations are possible (such as direct sunlight) is not recommended. Exposure to high ambient temperatures can cause the fusible links to break prematurely. (See chart 1 for link temperature ratings.)

Part Number	Yield Temp.	Max. Ambient Temp.
314135	135° F/57° F	104° F/41° C
314165	165° F/74° C	135° F/57° C
314212	212° F/100° C	185° F/82° F
314280	280° F/138° C	253° F/123° C
314360	360° F/182° C	330° F/166° C

Series	Links per assembly
FL-BT-149X	8



IMAGE OF FUSIBLE LINK

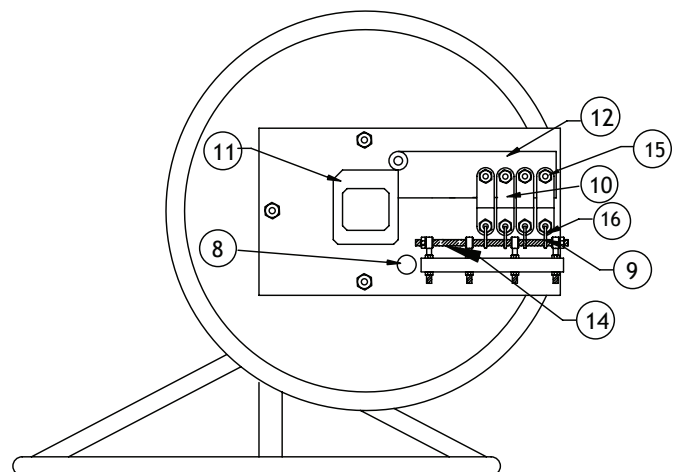

ILLUSTRATION 1.1
all reference numbers
refer to drawing FL-BT-0600



BT SERIES THERMAL SHUT-OFF VALVES

OPERATIONS AND MAINTENANCE MANUAL Models FL-BT-149X

III. INSTALLING FUSIBLE LINKS ON THE BT SERIES ASSEMBLY

NOTE: THE VALVES ARE SHIPPED IN THE CLOSED POSITION AND UNARMED AND MUST BE MOVED TO THE OPEN POSITION AND ARMED TO BE FUNCTIONAL.

PRE-ARMING CHECK LIST

- Is valve installed in line securely?
- Is Declutch gear override in the engaged position? (see page 4)
- Is the valve in the closed position?

If the items in the checklist all can be answered “YES”, proceed with arming the assembly.

FOR NEWLY INSTALLED AND UNARMED ASSEMBLY

REQUIRED TOOLS: 9/16” and 1/2” open-ended wrenches to install nuts (varies with spring pack) **NOTE:** INSTALL VALVE IN PIPELINE BEFORE PROCEEDING!

1. Move locking trigger (#12) away from spring pack tripper plate (#11) prior to opening valve.
2. With declutchable manual override gear in the engaged position, open valve with the handwheel. Turn the declutch gear handwheel toward the open position (CCW) until it stops. **CAUTION:** Keep declutch in engaged position.
3. After valve has been opened, swing locking trigger (#12) into position as shown on illustration FL-HT-0600-1.1 on page 3.
4. Remove hardware on locking trigger (#12) and secure fusible links to through holes on spring pack arming device (#7). **IMPORTANT:** Keep fusible links (#10) straight and in line while attaching to trigger (#12). **DO NOT OVERTIGHTEN.**
5. Adjust rod end nuts on retaining rods (#9) until a slight tension on the links is felt. **DO NOT OVERTIGHTEN.**
6. With declutch engaged, turn declutch handwheel clockwise (CW) until spring tension is held by links. Disengage declutch mechanism according to instructions on page 4. **DO NOT FORCE INTO POSITION.** The unit is now armed.

IMPORTANT: THE UNIT IS NOT ARMED UNTIL THE GEAR HAS BEEN PLACED IN THE DISENGAGED POSITION AFTER INSTALLATION OF LINKS. IF THE GEAR IS LEFT IN THE ENGAGED POSITION THE VALVE WILL NOT SPRING CLOSE.

IV. OPERATION

Once the unit is properly armed, the valve may be operated closed-open in the normal manner using the declutchable gear handwheel upon removal of the fusible links (reverse “Installation” instructions above). The gear lever must always be returned to the DISENGAGED position after manually operating the valve and the links must be put back into place. Failure to return the gear to the disengaged position will lock the gear and valve into position, and the fusible link assembly will not function properly.

IMPORTANT: THE FUSIBLE LINKS MUST BE RETURNED TO THE ARMED AND INSTALLED POSITION AFTER MANUAL OPERATION!

OPERATIONS AND MAINTENANCE MANUAL Models FL-BT-149X

V. MAINTENANCE

IMPORTANT: The fusible link manufacturer recommends annual replacement of link(s) as part of a regular maintenance schedule. Contact your local distributor or BI-TORQ® Valve Automation for replacement links. Order by part number or temperature rating on old link. Replacement valve seats and seals subject to normal wear are available from your local distributor or BI-TORQ Valve Automation. The spring case and declutchable gear are lifetime lubricated and do not require maintenance. Disassembly of the spring case or gear will void any written or verbal warranties.

WARNING: THE SPRING CASE CLOCKSING IS ALWAYS UNDER PRESSURE. DO NOT DISASSEMBLE SPRING PACK UNDER ANY CIRCUMSTANCES. DISASSEMBLY OF THE SPRING PACK COULD RESULT IN SERIOUS INJURY OR DEATH.

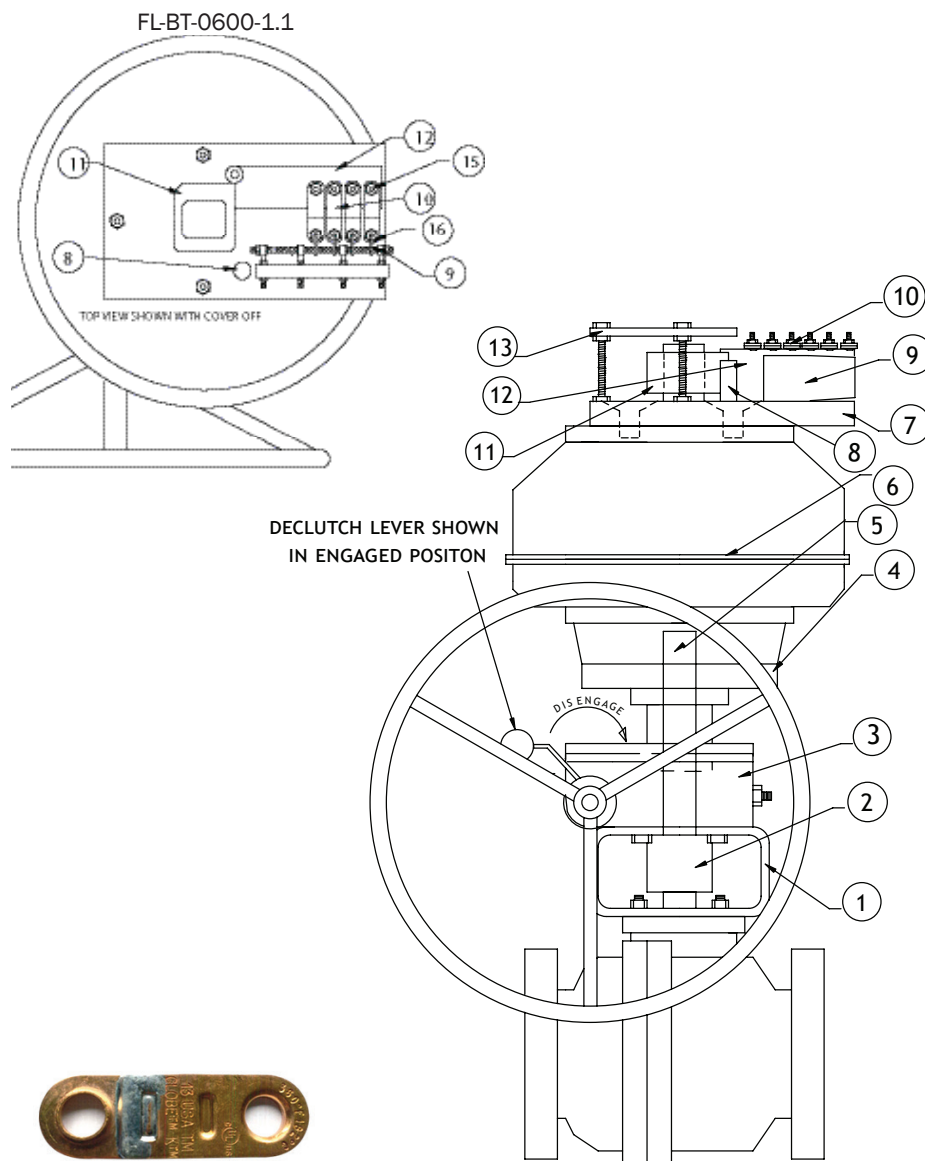

IMPORTANT: IMPROPER INSTALLATION OR ARMING OF FUSIBLE LINK ASSEMBLIES WILL VOID WARRANTY, AS WILL DISASSEMBLY OF THE PRODUCT WITHOUT PRIOR APPROVAL FROM FACTORY.

PARTS LIST

1	valve mounting bracket
2	valve coupler
3	declutchable override gear
4	spring pack mounting plate
5	spring pack/declutch coupler
6	spring pack (149, 169, 189)
7	arming device mounting plate
8	adjustable closed stop
9	fusible link retaining rod
10	fusible links
11	spring pack tripper plate
12	locking trigger
13	safety cover plate
14	rod end bearings
15	shoulder bolts
16	SuperLoops



IMAGE OF FUSIBLE LINK

ASSEMBLY DRAWING FL-BT-0600

OPERATIONS AND MAINTENANCE MANUAL Models FL-BT-149X

VI. OPERATING THE DECLUTCHABLE MANUAL OVERRIDE GEAR

IMPORTANT: Make sure that the fusible links have been removed before attempting to operate the valve with the declutchable manual override.

Use the following instructions to **ENGAGE** the declutchable manual override.

1. Using one hand, grab the override engagement handle, squeezing the bottom handle and top handle together.
2. With the handles still squeezed together, rotate the handle from its declutched position upward toward the spring pack mounting flange until the handle locking tabs are in line with their locking positions.

NOTE: In some cases the override gear teeth will not mesh correctly when rotating the handle upward. If this occurs, rotate the override handwheel slightly to mesh the gears and then rotate the declutch handle upward.

3. Once the override handle is in its locked position, the override is ready to be used. Clockwise rotation of the override handwheel will produce clockwise rotation of the override output and valve. Conversely, counterclockwise rotation of the handwheel will produce counterclockwise rotation of the override output, and valve.

Use the following instructions to **DISENGAGE** the declutchable manual override.

Note: When the assembly is rearmed with the fusible links back in place, the the manual override must be returned to its declutched position. Reversing the procedure above will return the override to the declutched position. Make sure that the handle locking tabs are inserted into their locking position on the override housing.

Leaving the declutch engaged will prohibit the spring return unit from cycling the valve to the closed position when the fusible links yield. Leaving the unit in the engaged position will prevent the unit from operating correctly, may cause damage to the override as well as drivers linkages, etc. and void the override warranty.

IMPORTANT: The fusible links will have to be reinstalled and the declutch disengaged before the assembly is properly armed.



DISENGAGED

The picture on the left shows the declutch operator in the disengaged to allow the spring pack to close the valve when the fusible links yield. As shown, the handle arrangement is pinned in the down position. The handwheel should rotate freely in either the clockwise or counterclockwise directions without affecting the valve rotation.



ENGAGED

The picture on the left shows the declutch in the “override” position, or “engaged,” for operating the valve manually. As shown, the handle arrangement is pinned in the up position for override. Rotation of the handwheel clockwise will rotate valve clockwise (generally closed direction); rotation of the handwheel counter-clockwise will rotate actuator counterclockwise (generally open).

IMPORTANT: FUSIBLE LINKS MUST BE REMOVED BEFORE ATTEMPTING TO OPERATE THE VALVE WITH THE DECLUTCH.